

Manuscript received March, 28, 2024; revised April, 21, 2024; accepted May, 10, 2024; date of publication June, 28, 2024

Digital Object Identifier (DOI): XXXX

This work is an open-access article and licensed under a Creative Commons Attribution-ShareAlike 4.0 International License ([CC BY-SA 4.0](https://creativecommons.org/licenses/by-sa/4.0/))



Design of a Data Logger with WEB-based Storage

Salmon¹, Nur Hasanah Ahniar¹, Vita Nurdinawati¹

¹Electromedical Technology, Health Polytechnic of Ministry of Health Jakarta 2, Indonesia

Corresponding author: Salmon (P2.20.30.1.22.928@poltekkesjkt2.ac.id)

ABSTRACT

Data Loggers are electronic devices continuously collecting and analyzing data from various sources. Some data loggers use personal computers and software as storage devices for data collection and analysis and are integrated with sensors and instruments. Data logging is the process of collecting and analyzing data from sensors to perform data analysis. SCADA (Supervisory Control And Data Acquisition) is the evolution of computer-based data logger systems, where data is stored in graphical form, allowing operators to analyze data easily. Data Loggers are usually used to maintain medical devices and monitor data in real-time. They can also be used as calibrators for medical devices such as vaccine refrigerators, medicine refrigerators, and autoclaves. This research aims to make a data logger tool with web-based storage and analyze data on the percentage of error and the percentage of temperature accuracy using a thermocouple comparison tool. Temperature sensors convert physical data into a list that can be accessed and analyzed using a computer or microprocessor. In this study, researchers made a data logger using ESP32 as a microcontroller and Ds18B20 as a temperature sensor. Recording temperature measurement data using a website includes temperature readings and graphs. In this study, the average temperature value on sensor (T) 1 was 4.30, with a percentage error of 0.08% and a percentage accuracy of 99.93%. Sensor (T) 2 produces an average temperature value of 4.09, with a percentage error of 0.02% and a percentage accuracy of 99.98%. Meanwhile, sensors (T) 3, and 4 produce the same average temperature value of 4.12, with a percentage error of 0.03% and a percentage accuracy of 99.97%. The largest percentage error is found in sensor (T) 1 because sensor (T) 1 is in the middle of the refrigerator while the other three sensors (T) are near the wall of the cooler, so there is a difference that is not too far from the temperature setting tool.

KEYWORD: Data logger, website, medical device

I. INTRODUCTION

The development of science and technology is currently very rapid, especially in technology that can help human work become easier and more efficient. Recording temperature, which is currently done manually, makes work inefficient. Especially if temperature recording is done continuously with real-time temperature recording [1]. In the health sector, it is usually used to record temperature statistics from a room, drug storage, vaccines, blood, etc. A tool, namely a data logger, is needed to make work more efficient and easier.

A Data Logger is an electronic device that functions to record data from time to time continuously. Some data loggers use personal computers and software as a place to

store data and analyze data. Data stored on the hard disk can be accessed whenever desired. This includes data acquisition devices such as plug-in boards or serial communication systems that use computers as real-time data storage systems. Most manufacturers consider a data logger a standalone device that can read various electronic signals and store the data in internal memory for later download to a computer.

Data logging is the process of automatically collecting and recording data from sensors for archiving or analysis purposes. Sensors convert physical quantities into electrical signals that can be measured automatically and eventually sent to a computer or microprocessor for processing[2].

They are usually small, battery-powered, portable, and equipped with a microprocessor and internal memory to store data and sensors. Some data loggers are interfaced with a computer and use software to enable the data logger to view and analyze the collected data. In contrast, others have their own interface equipment (keypads and LCDs) and can be used as stand-alone devices.

PC-based data loggers use a computer; usually, a PC is used to collect data through sensors to analyze and display the results. SCADA (Supervisory Control And Data Acquisition) is a further evolution of computer-based data logger systems, where data is presented in graphical form so that operators can supervise experiments or processes. In the world of health, data loggers are usually used to monitor a device that requires real-time monitoring. They are also used as a calibrator tool to calibrate devices such as vaccine storage, medicine refrigerators, and autoclaves.

Research that has been done before by Agus Dwi Korawan (2018). Designing a temperature data logger consists of 3 units; first is a temperature reader, data processor, and data storage. The results can be seen directly on the computer monitor screen and obtained by importing data stored in the SD Card [3].

Research done before by Agus Rianto and Roedy Kristiyono (2023). Designing a temperature detection device in a vaccine cooling room using Arduino Uno as a microcontroller, Ds18b20 temperature sensor, and storing temperature data in micro SD memory where the data can be seen in excel [2].

Based on this, this research will design a data logger tool using ESP32 as a microcontroller, Ds18b20 as a temperature sensor and storage via the web with the results in the form of numeric and graphical displays that can be accessed via a PC so that the operator does not need to import data again to the PC.

II. RESEARCH METHODS

A. Research Design

The method to be applied in this research involves making a framework, which will provide a concise description of the steps to be carried out [4]. These steps consist of tool design concepts, research flow, tool specification planning, tools and materials, block diagrams, working principles, hardware, software, and tool module specifications [5].

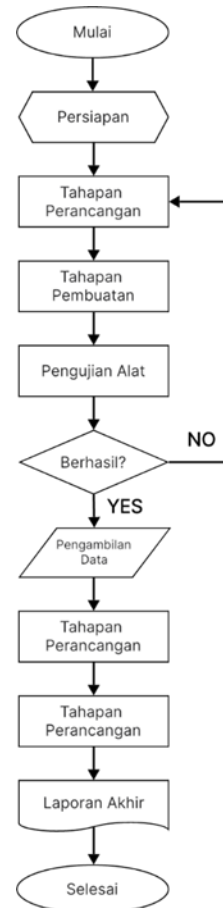

Figure 1: Research stages

The system block diagram on the design of the data logger as a vaccine refrigerator calibrator is seen in Figure 2.

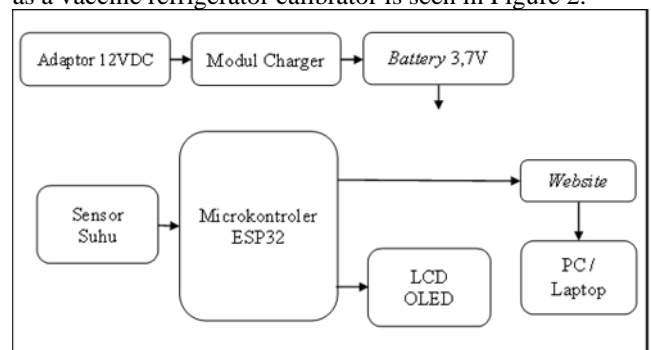

Figure 2. Block Diagram of Data Logger tool as Vaccine refrigerator calibrator

B. Flowchart Design

The following research flowchart design is made to show the process of the vaccine refrigerator calibrator tool from start to finish.

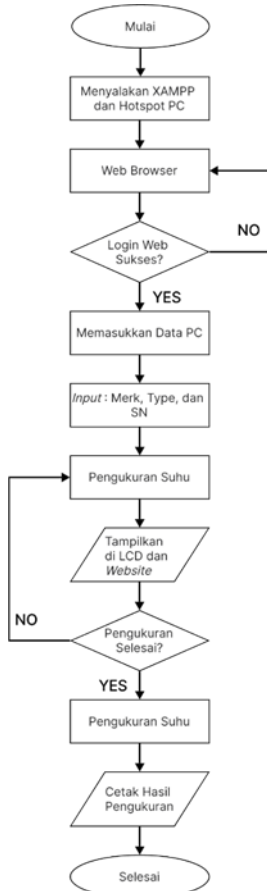

Figure 3. Flowchart of vaccine refrigerator calibrator tool

C. System Design

The system design uses several software, including XAMPP for the localhost server as a system place, then a worksheet system is made using the Codeigniter framework.

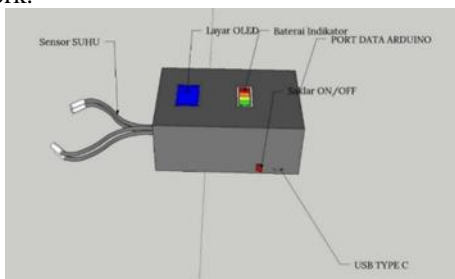

Figure 4. Design of data logger tool design

D. Data logger circuit design

The design of the data logger tool circuit is divided into 4 circuit groups, namely the Charger circuit, LCD circuit, and temperature sensor circuit and the overall circuit of the data logger tool [6].

1. TP4056 Charger circuit

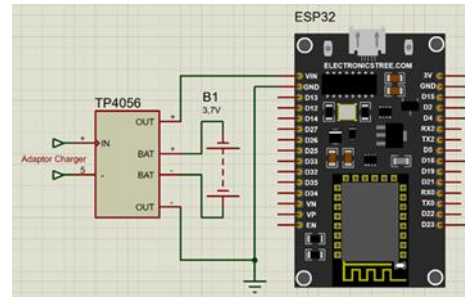

Figure 5. TP4056 Charger circuit

The battery charger circuit of the data logger tool functions to supply voltage to the Arduino and other components.

2. TFT LCD circuit

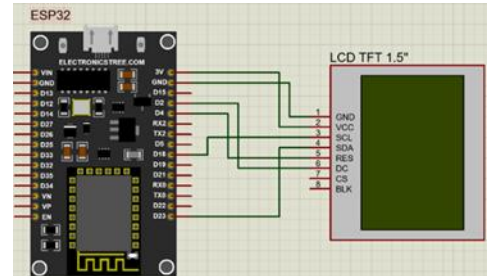

Figure 6. TFT LCD circuit

The LCD circuit gets a voltage input of 3 VDC on the VCC pin of the ESP 32.

3. DS18B20 temperature sensor circuit

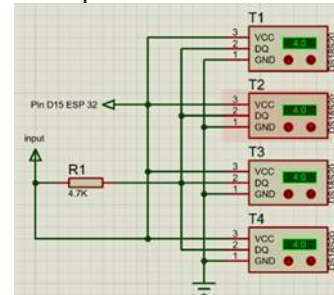

Figure 7. Ds18b20 temperature sensor circuit

The DS18B20 sensor provides a 9 to 12-bit (configurable) temperature reading that indicates the temperature of the device [7].

4. Overall circuit of the data logger tool

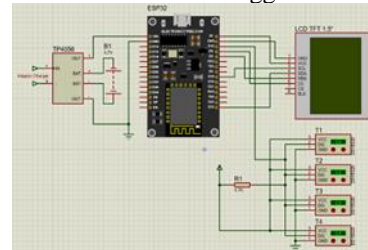

Figure 8. Data logger circuit

The DS18B20 temperature sensor will record and send analog data to the ESP 32 via pin D15 which is then processed by the ESP 32 into digital data.

III. RESULT AND EXPLANATION

A. Design Preparation

The design preparation stage pays attention to the list of components that will be used in the circuit, so that the components are suitable and there is no confusion in the process of testing and data collection of the Data Logger Design Tool as a Vaccine Refrigerator Calibrator with Web-Based Storage. The following components are used in the manufacture of this module:

Table 1. List of Materials

No	Nama	Jumlah
1	Sensor Suhu DS18B20	1
2	ESP 32	1
3	Resistor 4,7K	1
4	Saklar on/off	1
5	Battery	1
6	LCD TFT 1,5 inch	1
7	Modul charger TP4056	1
8	Box casing alat	1

The tools used are multimeter, toolset, 4 channel thermocouple.

B. Tool Design Results

1. Tool Specifications

The specifications of the Data Logger Design tool as a Vaccine Refrigerator Calibrator with Web-Based Storage are equipped with four temperature sensors. The four sensors are connected to the website to make it easier for users to record temperature data in the vaccine refrigerator.

2. Software Design Results

The design developed in this research is software using XAMPP for a localhost server as a system place, then making a website design using the Codeigniter framework.

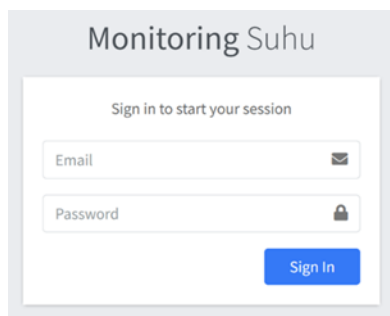

Figure 9. Website Login Page Design

Based on the picture above, is the result of the design to enter the website page before the temperature measurement is taken. After entering the website page the author makes a design for the next stage by inputting laptop data used for measurement. Then proceed with making a design for inputting tool data to be carried out, after that making the design of the initial page of the website after inputting data, and the last stage makes the monitoring page of the temperature measurement results on the four sensors equipped with graphs.

3. Physical Shape of Tool



Figure 10. The results of designing a data logger tool

The physical form of the tool uses 4 DS18B20 sensors and a plastic box as a tool casing.

C. Temperature Accuracy Testing and Data Collection

Testing and data collection on temperature accuracy consists of 4 tests, namely testing at the first 1 hour, testing at the second 1 hour, testing at the third 1 hour, and testing the temperature for 3 hours.

1. Testing and Data Collection of Temperature Accuracy in the First 1 Hour

Measurements are taken with a reading interval of once every 1 minute with a vaccine refrigerator temperature setting of 4°C through several stages (T) 1 - (T) 4, where the temperature sensor reading graph read on the device is not too different from the comparison tool and tends to be stable at all stages, but the difference is the average temperature and percentage error.

- At (T) 1 the module measurement results against the thermocouple tool as a comparison obtained an average result of 4.32°C with a percentage error of 0.005%. The temperature read on sensor (T) 4 shows a number that is 5°C.
- At (T) 2 the measurement results on the module against the thermocouple tool as a comparison obtained an average temperature of 4.07°C with a percentage error of 0.025%. The temperature read on the sensor shows 4°C.

- At (T) 3 the measurement results on the module against the thermocouple tool as a comparison obtained an average temperature of 4.20°C with a percentage error on the sensor (T)3 0.024%. The temperature read on sensor (T)3 shows 4°C .
- At (T)4 the measurement results on the module against the thermocouple tool as a comparison obtained an average temperature of 4.32°C with a percentage error on the sensor (T)4 0.024%. The temperature read on sensor (T)4 shows 4°C .

2. Testing and Data Collection of Temperature Accuracy at the Second 1 Hour

The second data collection is measured, because it has reached the temperature detected by the device has stabilized. The measurement time is carried out for 1 hour with a reading interval of once every 1 minute with a vaccine refrigerator temperature setting of 40°C .

- At (T)1 the measurement results on the module against the thermocouple tool as a comparison obtained an average temperature of 4.28°C with a percentage error on the sensor (T)1 0.009%. The graph of the temperature sensor reading (T)1 read on the tool is not too different from the comparison tool and tends to be stable. The temperature read on the sensor (T)1 shows 50°C .
- At (T)2 the measurement results on the module against the thermocouple tool as a comparison obtained an average result of 4.17°C with a percentage error on the sensor (T)2 0.013%. The temperature read on the sensor (T)2 shows the number 4°C .
- At (T)3, the average temperature result is 4.32°C with a percentage error on the sensor (T)3 of 0.021%. The temperature read on sensor (T)3 shows 4°C .
- At (T) 4, the average result is 4.32°C with a percentage error on the sensor (T)4 of 0.032%. The temperature read on sensor (T)4 shows 4°C .

3. Testing and Data Collection of Temperature Accuracy in the Third 1 Hour

In the third stage of data collection, direct measurements are taken. The measurement time is carried out for 1 hour with a reading interval of once every 1 minute with a vaccine refrigerator temperature setting of 40°C . In the third 1 hour measurement, it was found that there was not too much difference between the module and the thermocouple tool as a comparison tool.

- At (T)1 the measurement results on the module against the thermocouple tool as a comparison obtained an average temperature of 4.30°C with a percentage error on the sensor (T)1 0.010%. The graph of the temperature sensor reading (T)1 read on the tool is not too different from the comparison tool and tends to be stable. The temperature read on the sensor (T)1 shows 5°C .

- At (T)2 the measurement results on the module against the thermocouple tool as a comparison obtained an average temperature of 4.05°C with a percentage error on the sensor (T)2 0.025%. The temperature read on the sensor (T)2 shows the number 4°C .
- At (T)3 the measurement results on the module against the thermocouple tool as a comparison obtained an average temperature of 4.05°C with a percentage error on the sensor (T)3 0.023%. The temperature read on sensor (T)3 shows 4°C .
- At (T)4 the measurement results on the module against the thermocouple tool as a comparison obtained an average temperature of 4.12°C with a percentage error on the sensor (T)4 0.022%. The temperature read on sensor (T)4 shows 4°C .

4. Testing and Data Collection of Temperature Accuracy for 3 Hours

In the measurement for 3 hours there is a difference that is not too far between the module and the thermocouple tool as a comparison of the designed tool.

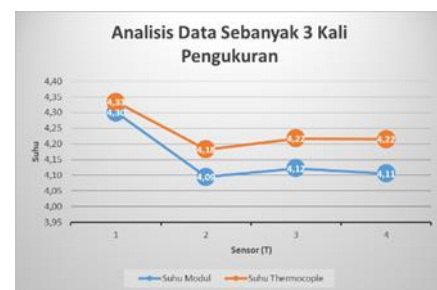

Figure 11. Average temperature for 3 measurements

Based on the figure above, the percentage of measurement error values on each temperature sensor in the vaccine refrigerator is still below the tolerance value with an error value on sensor (T) 1 of 0.30. This happens because sensor (T) 1 is in the center of the refrigerator while sensors (T) 2, 3, and 4 are placed on the edge of the vaccine refrigerator close to the cooling wall so that there is not too much difference in the temperature measurement with an error value of 0.10.

Calculation of the percentage error of sensor (T) in the module against the thermocouple tool as a comparison obtained the highest percentage error on sensor (T) 2 with a percentage error value of 0.021%. While the sensors (T) 1, 3, and 4 show the percentage error results of 0.008%, 0.023%, and 0.026%.

V. CONCLUSIONS

Based on the research results it can be concluded:

1. The temperature measurement results displayed on the module and thermocouple tool show the

difference in temperature measurement results that are not too far away.

2. The measurement results displayed on the LCD and website show the same results.
3. The highest percentage error results in sensor (T) 2 with a percentage error of 0.021%. While the sensors (T) 1, 2, and 3 show the percentage error results of 0.008%, 0.023%, and 0.026%.

REFERENCES

- [1] N. Lysbetti Marpaung and D. E. Ervianto, "Data Logger Sensor Suhu Berbasis Mikrokontroler ATmega 8535 dengan PC sebagai Tampilan," *J. Ilm. Elit. Elektro*, vol. 3, no. 1, pp. 37–42, 2012.
- [2] A. Rianto and R. Kristiyono, "PERANCANGAN TEMPERATUR DETEKSI DINI PADA RUANG PENDINGIN OBAT VAKSIN DENGAN TEMPERATUR DATA LOGGER MIKROKONTROL ARDUINO DENGAN SENSOR SUHU Ds18b20," *Teknika*, vol. 8, no. 1, pp. 9–16, 2023, doi: 10.52561/teknika.v8i1.196.
- [3] S. Wardoyo, R. Munarto, and V. P. Putra, "Rancang Bangun Data Logger Suhu Menggunakan Labview," *J. Ilm. Elit. Elektro*, vol. 4, no. 1, pp. 23–30, 2013.
- [4] P. WIBOWO and D. A. Prasetya, "Rancang Bangun Data Logger Multi Kanal Terhubung IoT (Internet Of Things) Sebagai Pengukur Temperatur dengan Sensor Thermocouple," *Emit. J. Tek. Elektro*, vol. 21, no. 2, pp. 87–94, 2021, doi: 10.23917/emit.v21i2.13773.
- [5] P. A. Satriya Guna Adnyana, R. Sari Hartati, and I. G. Dyana Arjana, "Rancang Bangun Data Logger Monitoring Vibrasi Pada Motor Listrik 6,3 Kv Berbasis Iot Secara Real Time Di Pltu Jeranjang," *J. SPEKTRUM*, vol. 9, no. 1, p. 121, 2022, doi: 10.24843/spektrum.2022.v09.i01.p14.
- [6] V. H. Juli, "Technologica," vol. 1, no. 2, pp. 65–71, 2022.
- [7] S. Kusumo, "Penerapan Web Scraping Deskripsi Produk Menggunakan Selenium Python Dan Framework Laravel," *JATISI (Jurnal Tek. Inform. dan Sist. Informasi)*, vol. 9, no. 4, pp. 3426–3435, 2022, doi: 10.35957/jatisi.v9i4.2727.